

Installation Manual

Neo Advance®

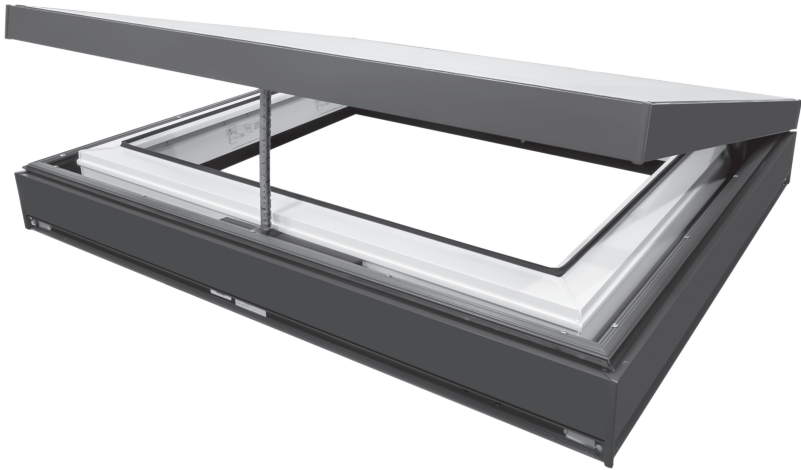

Opening Frame Option

INTRODUCTION

Thank you for choosing the Neo Advance® Rooflight. We are sure that the Neo Advance® Rooflight will provide a high-quality finishing touch to your project. This guide is a step-by-step guide to installing the **OPENING FRAME** version of the **Neo Advance® Rooflight**.

The step-by-step process must be followed in numerical order to ensure the installation is correct. Every project is different therefore it may be necessary to adapt the installation to suit the structure.

What you need to know about the Neo Advance® Rooflight:

- Installed at a maximum pitch of 15 degrees and a minimum of 3 degrees.
- The following installation details pertain to a membrane roof finish, installed on a timber kerb.

All of the images in this guide are diagrammatic (with some components omitted for clarity). They should be used as a reference. Installation instructions are regularly reviewed and we reserve the right to update or amend these details without alteration to this guide.

CARE AND MAINTENANCE

To achieve the maximum service life from the Neo Advance® (Flat Opening) rooflight it is important that scheduled care and maintenance is undertaken. Please note that the guarantee will become void if the procedures outlined in the separate maintenance manual are not adhered to. Please refer to the Operations and Maintenance Guide for further details.

ADVISORY



Standard rooflight. All the information provided in this document refers to a standard specification Neo Advance® (Flat Opening) rooflight.



Install in accordance with national building regulations / codes. This manual is an installation suggestion and installers should verify 'fitness for purpose' in accordance with all applicable regulations / standards at time of installation.



Structural support: structural supports for the Neo Advance® (Flat Opening) rooflight are to be designed and supervised during construction by the rooflight installer or project structural engineer. Nothing in this manual constitutes a structural proposal. Sizing / positioning of structural supports should be determined by the project's suitably qualified structural engineer.

Inside the box you will find your Neo Advance® (Flat Opening) Rooflight, the rooflight fixing kit, the rooflight power supply unit (PSU), a printed copy of this installation manual, the power supply unit installation manual and the motor reference manual.

- ⚠ Ensure you check the rooflight for any damage PRIOR to commencing the installation.
- ⚠ Report any damage to the courier and inform The Rooflight Co.
- ♻ Please recycle the cardboard box appropriately.
- ⚠ We recommend you retain the installation manual for future reference.

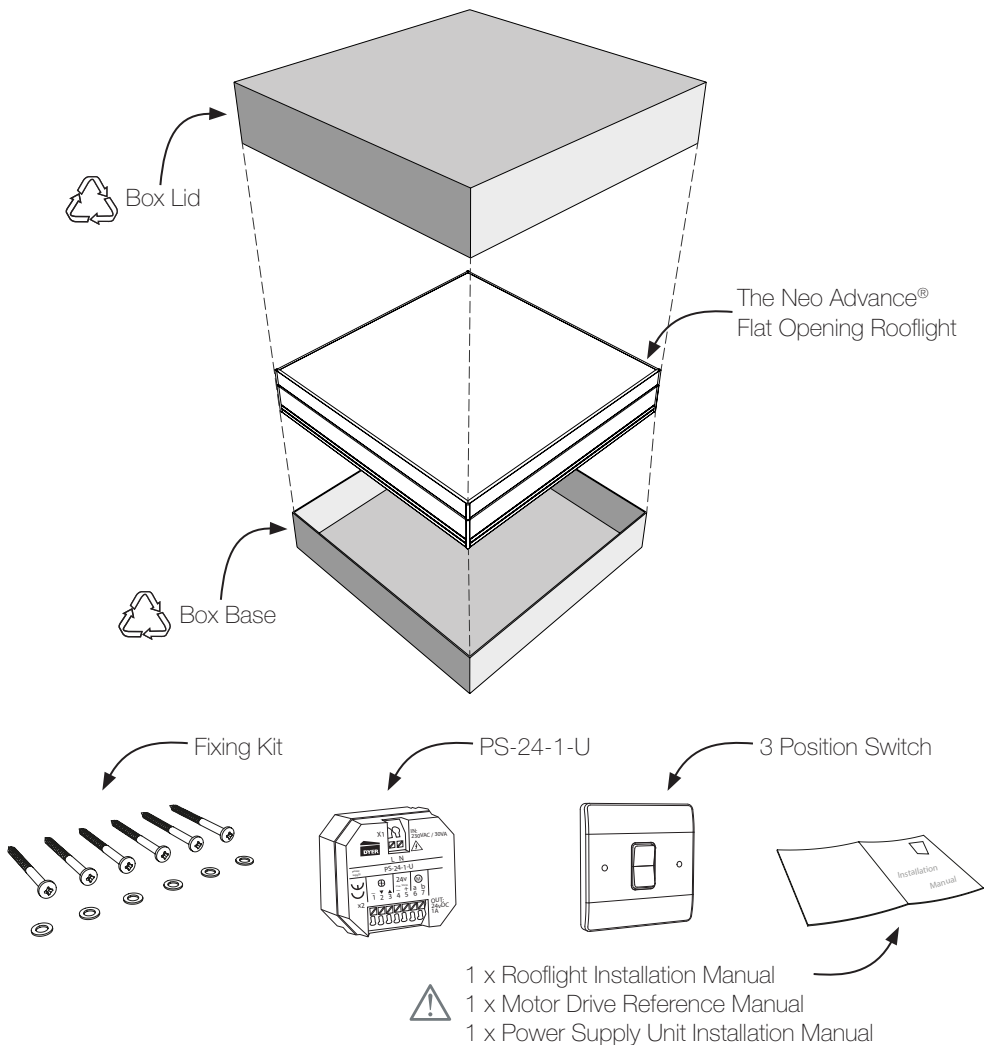

1.

Step 1 - Preparing the structure

1A. Prepare the roof structure and opening to your preferred specification. An example structure is shown below.

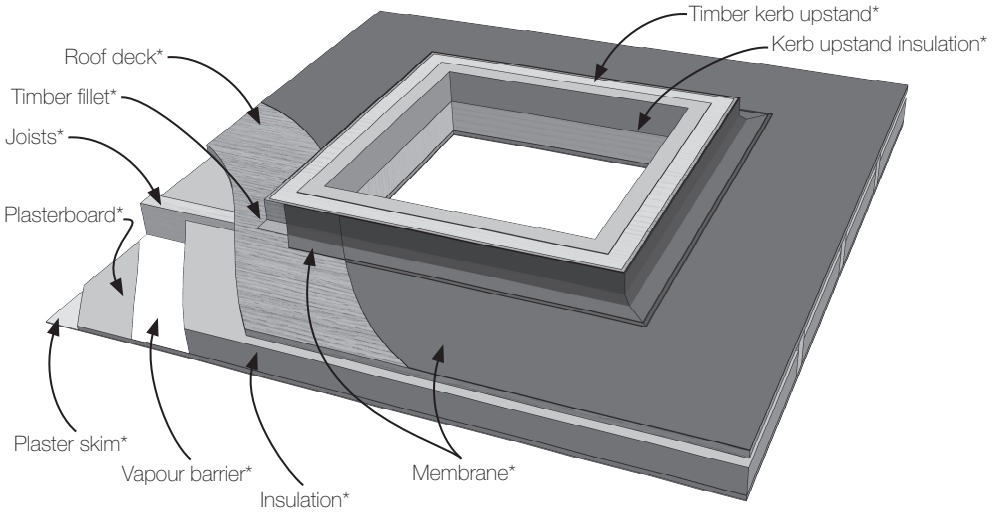

* All components detailed are supplied by others.

2.

Step 2 - Sectional reference details

2A. The example structure detailed in step 1 is shown below in 2D sectional view.

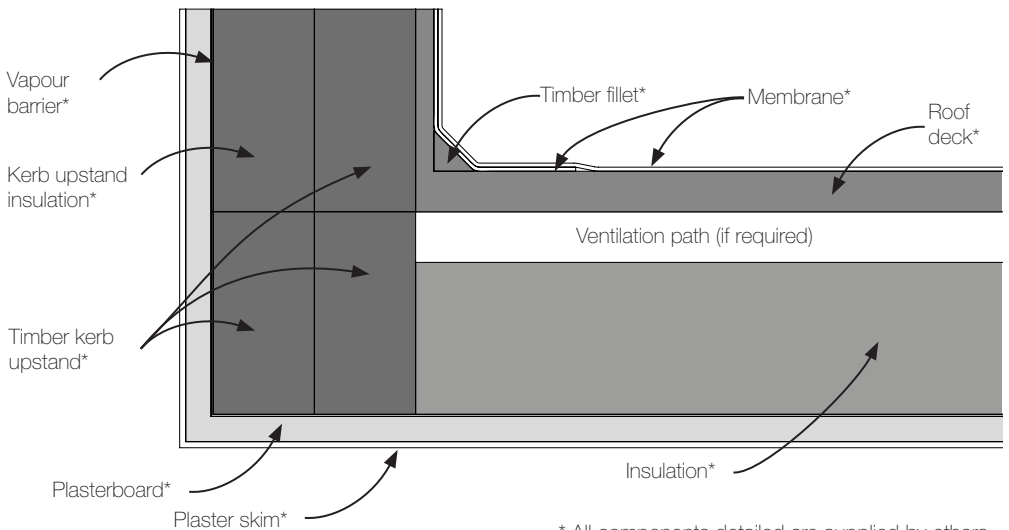

* All components detailed are supplied by others.

3.

Step 3 - Kerb dimensions

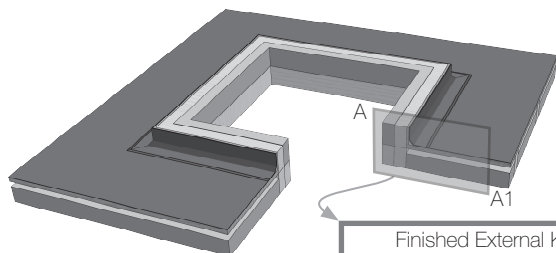

3A. The kerb width (including internal finish and external covering) must be **no greater than 130mm**. See detailed installation in Appendix A for more information.

3B. The kerb height should be constructed in accordance with the guidance provided in BS6229.

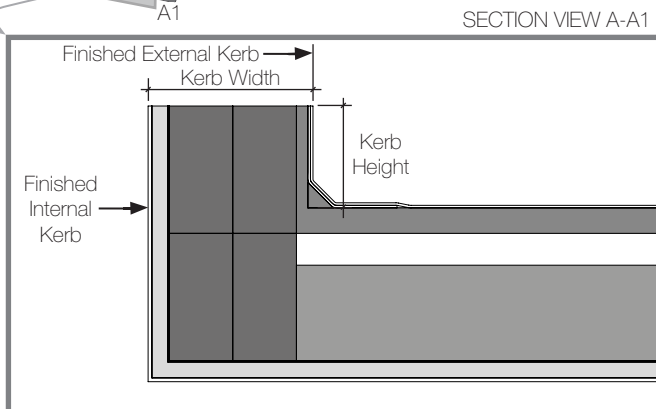

4.

Step 4 - Cable exit positions

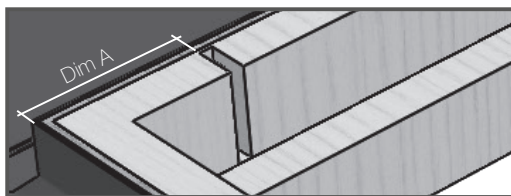

4A. A 25mm wide recess / hole must be inserted into the timber kerb to allow the cable of the motor to freely exit the underside of the rooflight frame. The recess should be located directly underneath the cable exit point. For the suggested installation detail shown in this guide:

Dim A (from external kerb edge) = 170mm

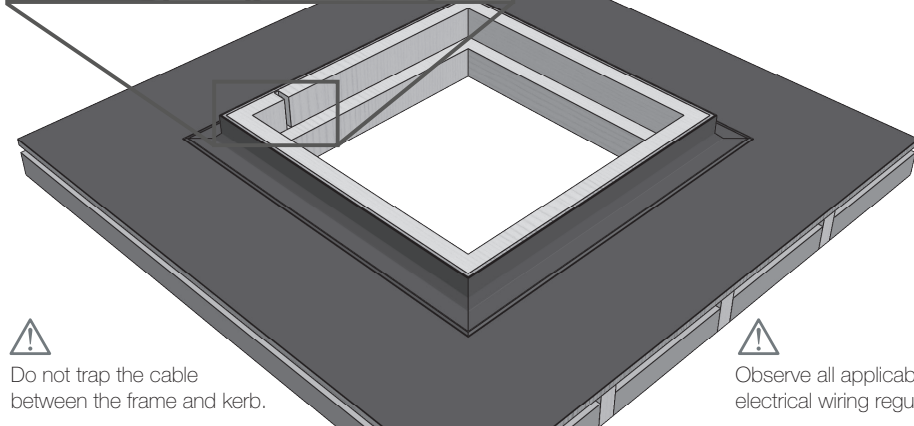

Do not trap the cable between the frame and kerb.



Observe all applicable electrical wiring regulations.

5.

Step 5 - Levels and falls

5A. Measure kerb across corners to check dimensional accuracy.



Kerb must fall by 3 degrees minimum to prevent water pooling on glass.

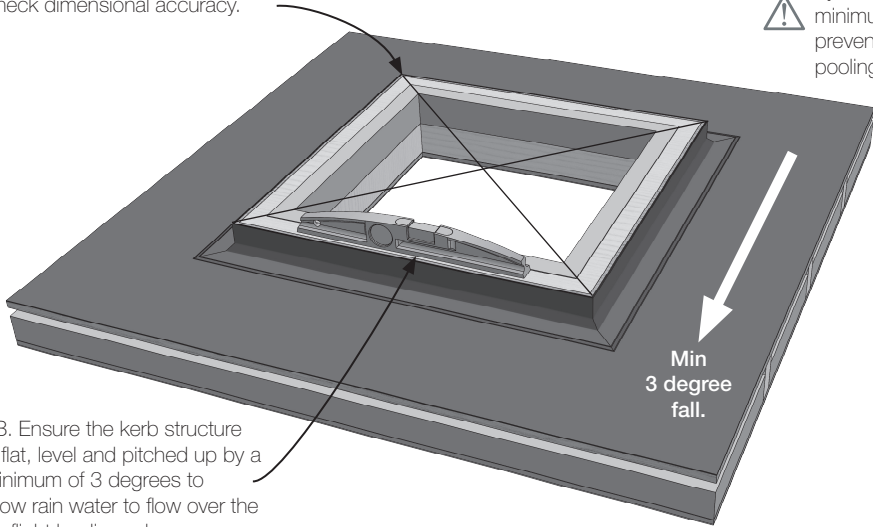

5B. Ensure the kerb structure is flat, level and pitched up by a minimum of 3 degrees to allow rain water to flow over the rooflight leading edge.

6.

Step 6 - Removing cover trim

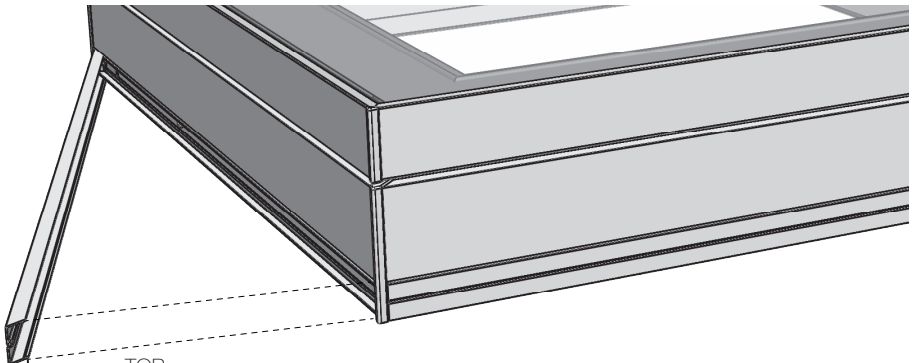

6B. Prise the trim from the rooflight taking care not to bend or damage the trim.

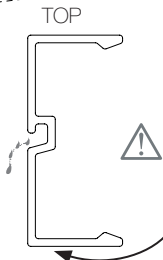

6C. Repeat for all four sides of the rooflight frame. Keep the trim profiles in a safe place for re-attachment later.

The cover trim has a top and bottom face - please take note of the orientation when re-attaching the trim profiles.

6A. Starting at one end of the cover trim - un-clip by pulling on the underside of the profile and rotating toward you.

7.

Step 7 - Silicone sealing

7A. Apply a generous bead of silicone sealant to the top face of the kerb prior to lowering the rooflight into place.



Do not trap the cable between the frame and kerb.

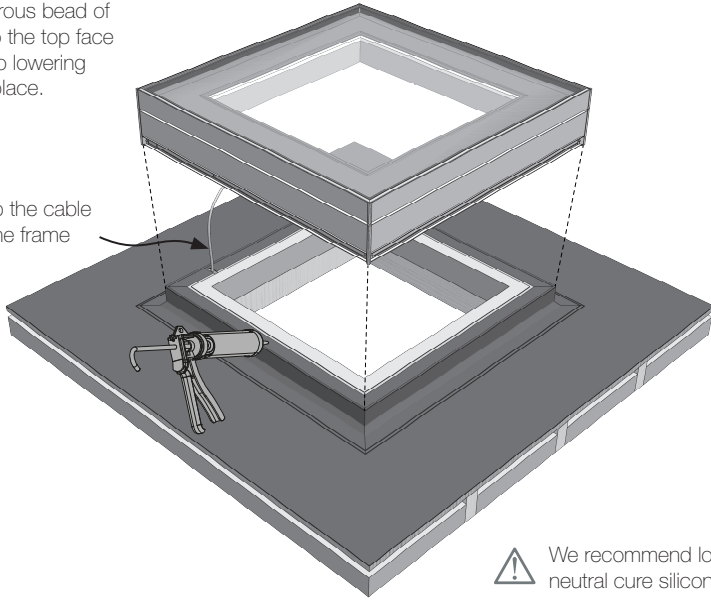

We recommend low modulus neutral cure silicone sealant.

8.

Step 8 - Product position and orientation



Ensure cill of rooflight is orientated at the lower end of the kerb fall.



Do not trap the cable between the frame and kerb when lowering.

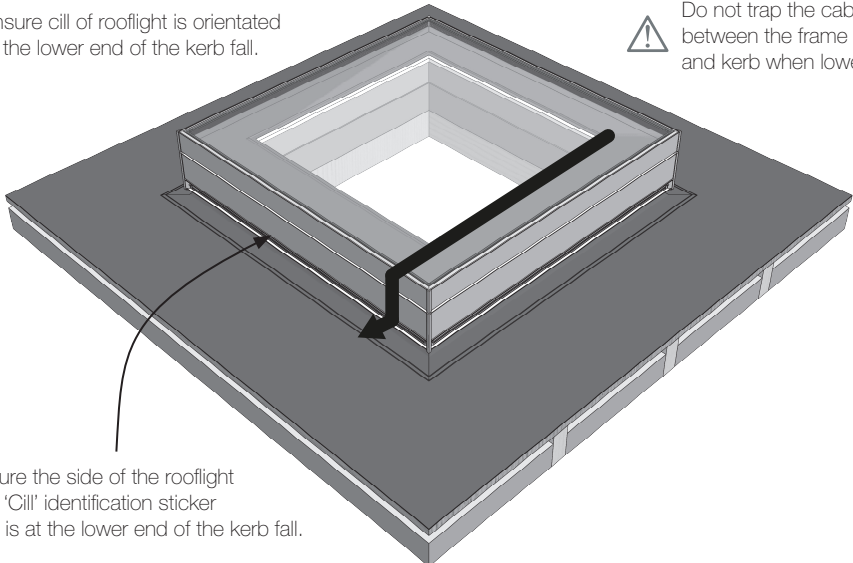

8A. Ensure the side of the rooflight with the 'Cill' identification sticker applied, is at the lower end of the kerb fall.

8B. Lower the rooflight frame on to the kerb upstand ensuring an even gap to all sides.

9. Step 9 - Fixing the rooflight

9A. Drill pilot holes into the timber kerb through the pre-drilled holes in the rooflight frame fixing channel.

9B. With packers in place behind the fixing channel, secure the rooflight frame using the wood screws provided.



Do not overtighten screws or deform the rooflight frame. Ensure packer is in place before tightening screws.

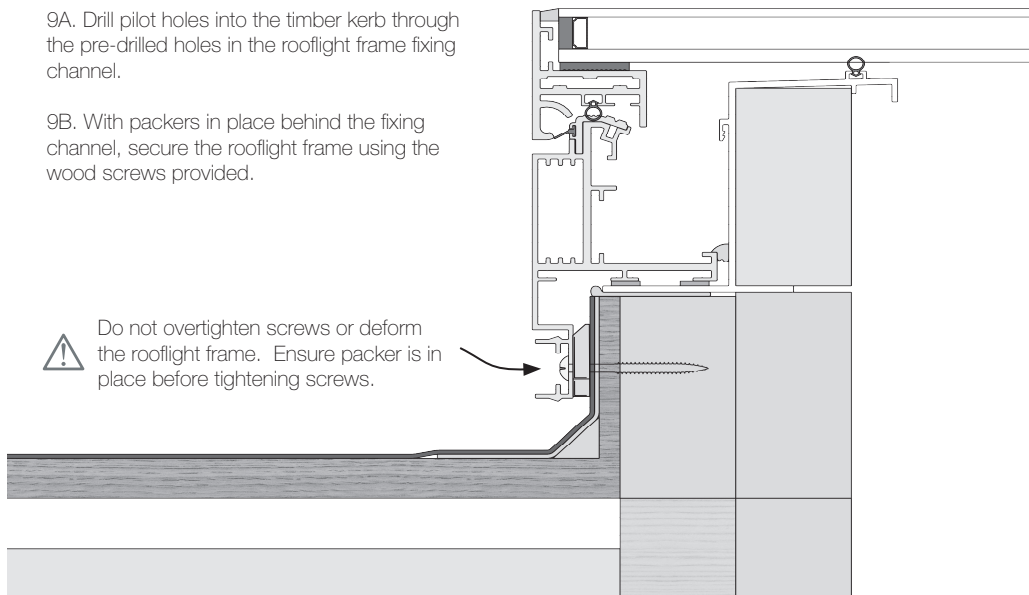

10. Step 10- Replacing the cover trim

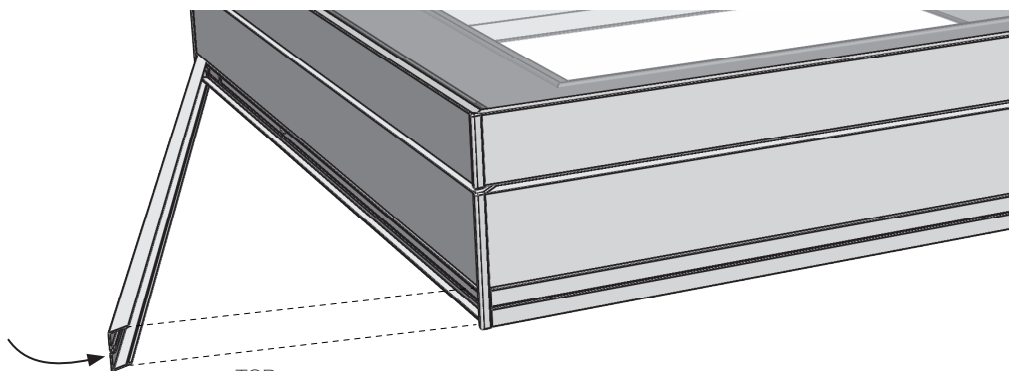

10A. Locate each of the previously removed cover trims and align to one end of the rooflight frame.



10B. Push the cover trim on to the frame. An audible 'click' will be heard when fully fitted. Press along the entire length of the trim to ensure it is fully engaged onto the rooflight frame.



The cover trim has a top and bottom face - please take note of the orientation when re-attaching the trim profiles.

11.

Step 11 - Internal vapour barrier

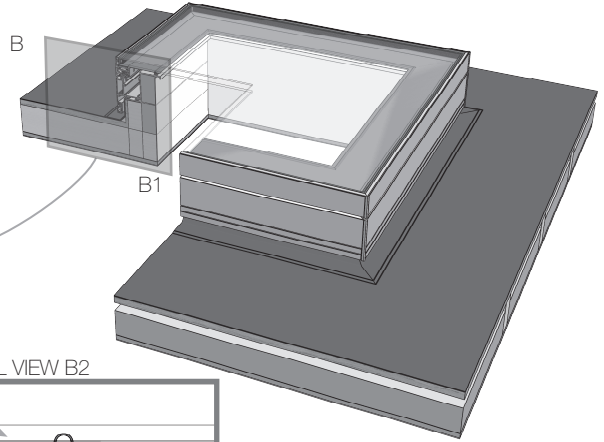

SECTION VIEW B-B1

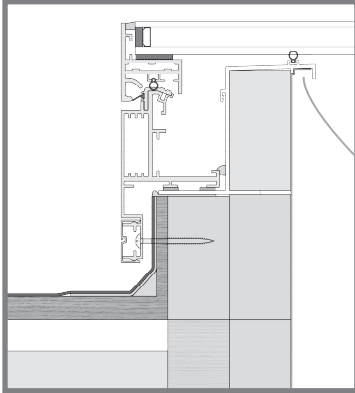

DETAIL VIEW B2

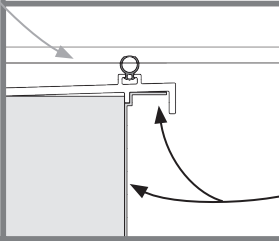

11A. Secure the vapour barrier into the plasterboard recess in the rooflight frame.

12.

Step 12 - Internal finish

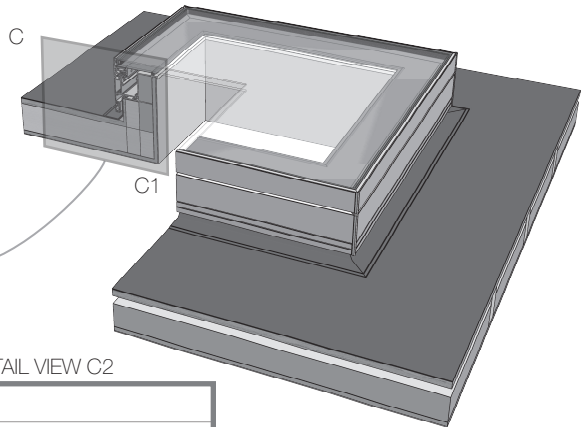

SECTION VIEW C-C1

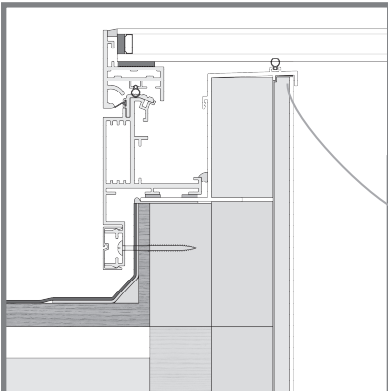

DETAIL VIEW C2

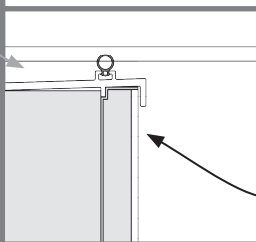

12A. Insert the plasterboard into the recess in the rooflight frame. Ensure the vapour barrier is held in position between the rooflight frame and the plasterboard. Skim as required.

13.

Step 13 - Motor wiring and test

13A. Connect the cable protruding from the underside of the rooflight frame to the supplied power supply unit (PSU) as per the separate instructions provided in the PSU box. For a standard installation of single rooflight, PSU and switch - the connection details are shown below for reference:

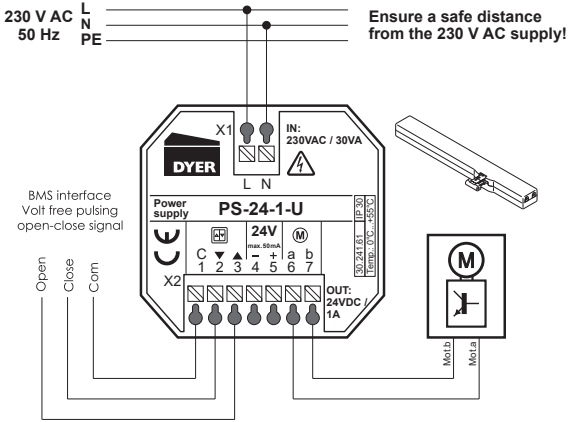

⚠ Only connect a 24V DC supply to the rooflight motor system.

⚠ Electrical connections only to be made by approved electrical contractor in accordance with applicable national regulations / codes.

⚠ Please refer to separately supplied technical and safety documentation prior to installation.

⚠ If your installation involves a rain sensor or group set-up then please disregard the connection details on this page and refer solely to the connection details provided with the PSU.

14.

Step 14 - Last steps

14A. Finally, clean the product to remove any dirt that may have accumulated during the installation process.

⚠ Ensure there are no contaminants on the glazing or painted frame.

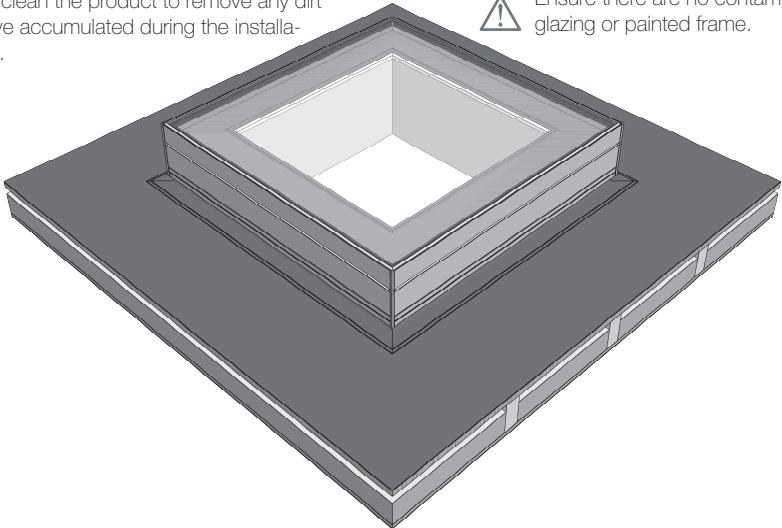

For any queries regarding installation please contact The Rooflight Co or visit www.therooflightco.com

Installation Manual

Neo Advance®

Opening Frame Option

Please register your product at:
www.therooflightco.com

Unit T1, Bourton Industrial Park
Bourton-on-the-Water
Gloucestershire
GL54 2HQ

T: 01993 833155
E: hello@therooflightco.com
www.therooflightco.com

THE
ROOFLIGHT CO.
COTSWOLDS



KM 93754
BS EN 1279-2, BS EN 1279-3



Assessed to ISO 9001:2015 Cert/LPCB ref. 929

In the interest of continuous product development, it may be necessary to amend specification without alteration to technical literature.

All drawings and designs are the Copyright and Design right of The Metal Window Company Ltd.